

CLEVIS ROLLER HANGER

Model 679

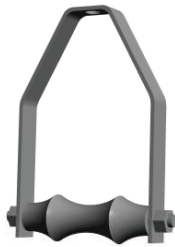

SIZE:

2" thru 24"

FINISH:

Plain

FUNCTION:

Designed for the suspension of pipe where longitudinal movement of pipe may occur due to expansion and contraction, and where vertical adjustment may be necessary

FEATURES:

- Maximum temperature 450° F
- Designed to be compatible with Elite Components Roller
- Conforms with Federal Specification A-A-1192A (Type 41/43), W-W-171-E (Type 42/44), Manufacturers Standardization Society (MSS) SP-58 and SP-69 (Type 41/43)

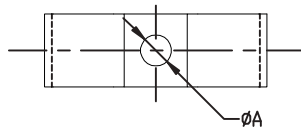
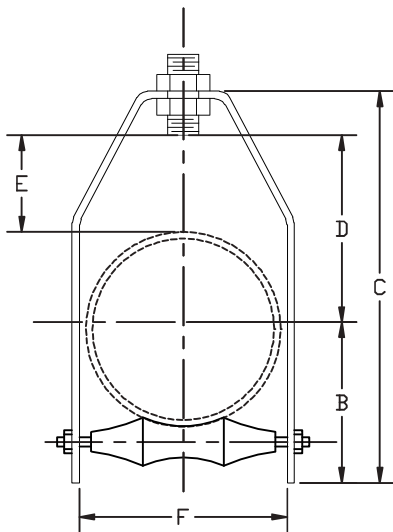

Clevis Roller Hanger: Loads (LBS) • Weights (LBS) • Dimensions (IN)

ITEM CODE PLAIN	SIZE	MAX LOAD	WEIGHT	A	B	C	D	E	F
679-0200P	2	150	1.23	3/8-16	1 1/16	4 3/4	2 3/8	1 7/16	2 7/8
679-0250P	2 1/2	225	1.78	1/2-13	1 7/8	6	3 3/16	2	3 1/4
679-0300P	3	310	2.06	1/2-13	2 3/16	6 5/8	3 1/2	2	3 3/8
679-0400P	4	475	3.44	5/8-11	2 3/4	7 7/8	4	2	4 7/8
679-0500P	5	685	6.00	5/8-11	3 3/8	9 3/16	4 9/16	2	5 15/16
679-0600P	6	780	8.00	3/4-10	3 15/16	10 3/8	5 1/16	2	7
679-0800P	8	780	13.00	3/4-10	5 1/16	12 5/8	6 1/16	2	9
679-1000P	10	965	16.00	7/8-9	6 1/4	14 15/16	7 3/16	2 1/16	11 1/8
679-1200P	12	1200	26.00	7/8-9	7 3/8	17 3/8	8 3/8	2 1/4	13 3/8
679-1400P	14	1200	34.00	1-8	8 1/4	19	8 3/4	2 1/4	14 1/2
679-1600P	16	1200	39.00	1-8	9 1/4	20 3/4	9 3/4	2	16 3/8
679-1800P	18	1400	49.00	1-8	10 3/8	23 11/16	11 7/16	2 11/16	18 3/8
679-2000P	20	1600	66.86	1 1/4-7	11 1/2	25 7/8	12 1/4	2 1/2	20 3/8
679-2400P	24	1800	116.30	1 1/2-6	13 13/16	31 1/16	15	3 1/2	24 5/8